

## A New Advanced One-Unit VLBI Correlator (NAOCO)

Katsunori SHIBATA<sup>1</sup>, Tetsuo SASAO<sup>1</sup>, Noriyuki KAWAGUCHI<sup>2</sup>, Yoshiaki TAMURA<sup>1</sup>,  
Seiji KAMENO<sup>3</sup>, Makoto MIYOSHI<sup>2</sup>, Kazuyoshi ASARI<sup>1</sup>, Seiji MANABE<sup>1</sup>,  
Tadayoshi HARA<sup>1</sup>, Seisuke KUJI<sup>1</sup>, Katsuhisa SATO<sup>1</sup>, Takeshi MIYAJI<sup>2</sup>,  
Kin'ya MATSUMOTO<sup>4</sup>, Yoshiharu ASAKI<sup>4</sup>, Shigeru YASUDA<sup>5</sup>  
and Saburoku NAKAMURA<sup>6</sup>

<sup>1</sup>Mizusawa Astrogeodynamics Observatory/NAO, Mizusawa, Iwate 023, Japan

<sup>2</sup>Nobeyama Radio Observatory/NAO, Minamisaku, Nagano 384-13, Japan

<sup>3</sup>Faculty of Science, Tokyo University, Bunkyo, Tokyo 113, Japan

<sup>4</sup>University of Electro-Communications, Chofu, Tokyo 182, Japan

<sup>5</sup>Faculty of Engineering, University of Kagoshima, Kagoshima 890, Japan

<sup>6</sup>School of Science, Nagoya University, Nagoya, Aichi 464-01, Japan

**Abstract.** A new K-4 based VLBI cross-correlation processor was successfully developed at National Astronomical Observatory. Although compact and transportable, the correlator has 512 complex lags, 128 Mbps maximum processing speed, pulsar gating function and capability of processing 2-bit sampled records. Because of a simple one-unit architecture of the correlator, it is possible to process both 16-channel data with 8 Mbps per channel playback speed and single-channel data with 128 Mbps speed. Also, the search window is extendable up to 16 times in both lag and rate directions.

### 1. Introduction

A new K-4 based VLBI cross-correlation processor called NAOCO (New Advanced One-unit CORrelator) is now operational at NAO and Geodetic Survey Institute of Japan.

A single baseline model of NAOCO consists of three units: two correlator interface units and a correlation unit. Each unit is 30 cm high and weighs 27 kg. Although compact and fully transportable, NAOCO has a number of technological elements characteristic of modern VLBI correlators.

A guiding idea in the development of NAOCO was to create a handy “field instrument” for the world VLBI community (KAWAGUCHI *et al.*, 1991). Major specifications of NAOCO are

- 1) 128 Mbit/sec maximum processing speed,
- 2) 512 complex lags,
- 3) 4 MHz maximum fringe frequency,
- 4) correlation of 2 bit quantized data,
- 5) extension of the fringe search window up to 16 times,

- 6) extendable up to 5-station 10 baseline processor,
- 7) applicable to all K-4 and Mark III recording modes,
- 8) pulsar gating,
- 9) compact,
- 10) transportable.

Processing of Mark III data has not been implemented yet. In view of the efforts in the world VLBI community to define common interface for compatibility of existing and planned recording systems, it is better to postpone the development of the Mark III adapter till the realization of the common interface.

The number of complex lags, 512, would appear too large if one intends to ease the fringe search for existing systems only. In actuality, the large number of lags is indispensable for processing 2 GHz super-wideband record of K-4 Burst Mode VLBI system (see reports by MATSUMOTO and KAWAGUCHI in this volume), to which NAOCO is optimized. Capability of NAOCO to extend the search window in lag and/or rate directions up to 16 times will greatly ease the search works even for the Burst Mode data. Moreover, the lag extension, together with the capability of processing 2-bit quantized data, makes NAOCO a very powerful high-resolution VLBI correlation spectrometer with 8192 complex lags for 1-bit quantized data or 4096 lags for 2-bit quantized data.

## 2. One-Unit Architecture

A central conception in the hardware design of NAOCO is the one-unit architecture. NAOCO has only one correlation unit unlike ordinary Mark III type correlators which have as many correlation units as data channels.

In the Burst Mode VLBI system, the most important recording mode will be the single channel burst sampling mode. Therefore, the one-unit architecture similar to that of Mark II system but with much higher processing speed was a natural choice.

Having a high-speed one-unit correlator, however, we can process multichannel data as well, in terms of converting the channel-parallel data stream into a high-speed channel-serial data stream and use the correlator cyclically to process channels one by one. In particular, we can process K-4 type 0 data with 16 frequency channels (Fig. 1).

This function is realized in the correlator interface unit. The interface unit is a "station-based" unit where multi-channel data stream from each playback system is preprocessed in a programmable logic device called "bit rearranging subunit" and stored in one of the 64 Mbit  $\times$  2 toggle memories.

When the first memory gets full, the input data stream is switched to the second one and the random access to the first memory yields the channel serial data stream.

The same random access capability can be used also to process any parallel data with 8 channels, 4 channels and 2 channels. Moreover, we can repeatedly read out and process a small segment of a time series, shifting the initial read-out address by 512 bits and/or changing a priori rate parameters. Thus we can extend the search window up to 16 times in delay and rate directions and also get the capability of the correlation spectrometer with 8192 complex lags.

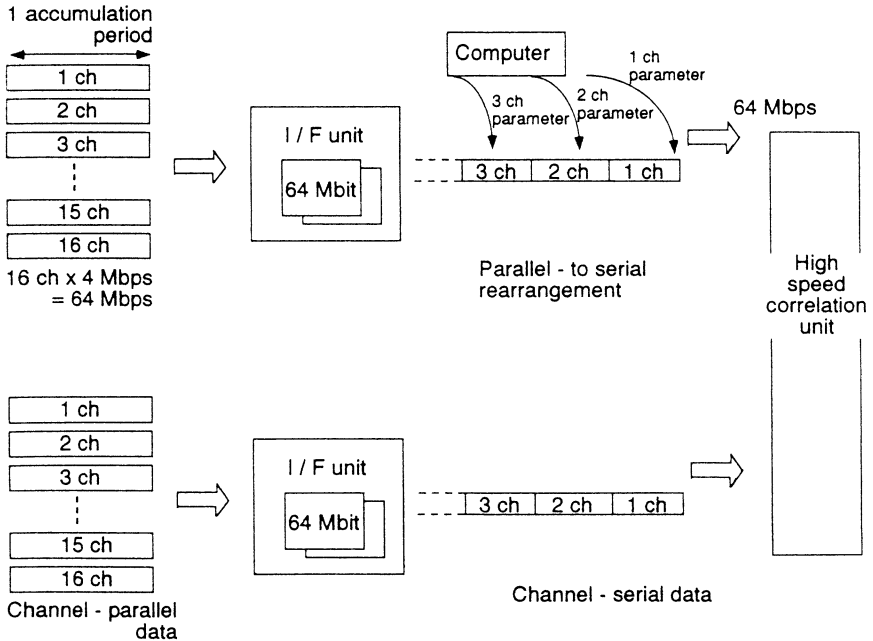

Fig. 1. Processing of multi-channel data with a single high-speed correlation unit.

### 3. 8 bit Parallel Processing

The correlation unit is a XF-type cross-correlation processor with “baseline-based” delay-tracking and fringe-rotation subunits. A remarkable feature of this unit is its high processing speed supported by 8-bit parallel (or byte-based) circuits.

For example, the byte-based cross-correlation integration is performed by custom-designed LSI's. Each LSI chip performs correlation integrations for 8 complex lags in a circuit schematically drawn in Fig. 2. Two successive bytes from Y-data are combined to form 16-bit data. A selector picks up 8 parallel bytes from the 16-bit data, which are consecutively shifted one from another by 1 bit. Then each byte is correlated with a X-data byte in one of 8 match counters. Thus we get complex cross-correlations for 8 lags. Since 1-byte-shifted Y-data are sent to the next LSI, we get 512 lags by serially combining 64 LSI chips.

The LSI is designed basically for correlating 1-bit quantized data. However, Kawaguchi found a beautiful algorithm to use the same circuit for processing the 2-bit quantized data. Number of lags is halved when the 2-bit quantized data are processed in the algorithm, but we get 20% improvement of sensitivity in return for spectral line observations.

A 68040 processor and 27.6 Mbyte RAM are included in the correlation unit for post-processing of the outputs from the correlation counters.

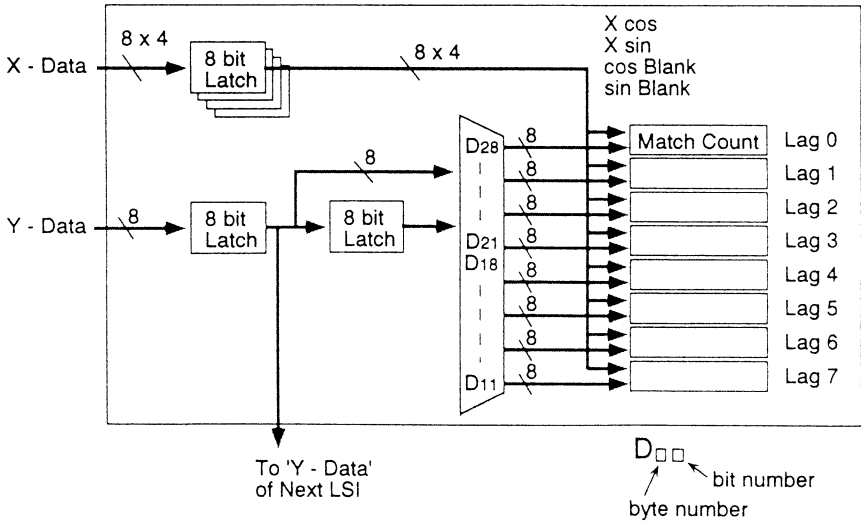

Fig. 2. Byte-based cross-correlation LSI.

#### 4. Software Development

Present software status of NAOOCO is given in TAMURA *et al.* (1993). We are now in position to readily process single baseline K-4 type 0 observations one by one. However, continuous automated processing of many observations is not available yet. Search window extension and other advanced functions of NAOOCO have been successfully tested. But software which would routinely handle these functions has not been implemented yet.

We plan to develop software system for routine operation of NAOOCO. Major goals of the development are

- (1) Automated processing of experiments following schedules and logs.
- (2) Accurate apriori parameters for Burst Mode or mm-wave observations.
- (3) Use of 68040 processor for normalization of correlated results.
- (4) Bandwidth synthesis.
- (5) Unified data management and data formats.
- (6) Full support of advanced functions of NAOOCO.
- (7) Multi-baseline processing.

Development of items 1–5 is now underway and we hope that the first version of the new software will be running in this winter.

#### REFERENCES

- KAWAGUCHI, N., MIYAJI, T., SASAO, T., HARA, T., KUJI, S., SATO, K.-H., TAMURA, Y., ASARI, K., KAMEYA, O., IWADATE, K., ABE, S., YASUDA, S. and MATSUMOTO, K., 1991. A High Performance Trans-

portable VLBI Correlator, *NOAA Technical Report No. 137 NGS 49, Proc. AGU Chapman Conference on Geodetic VLBI: Monitoring Global Change*, 82–89.

- MATSUMOTO, K. and KAWAGUCHI, N., 1994, Development of the burst mode VLBI, in this volume.
- TAMURA, Y., KAWAGUCHI, N., SASAO, T., HARA, T., KUJI, S., SATO, K-H., ASARI, K., MIYAJI, T., YASUDA, S., MATSUMOTO, K., KAMENO, S. and NAKAMURA, S., 1993, High Performance VLBI Correlator in NAO, *Proc. International Workshop for Reference Frame Establishment and Technical Development in Space Geodesy*, 121–124.